



Protector[®] Glove Boxes



Protecting your
laboratory environment

LABCONCO[®]

Protector® Glove Boxes

INTRODUCTION

Table of Contents

Overview	Inside front cover
Selection Guide	3
Protector Filtered Glove Boxes	
Introduction.....	4
Features & Benefits	5
Specifications	6
Ordering Information	7
Dimensional Data.....	8
Accessories	9
Protector Controlled Atmosphere Glove Boxes	
Introduction.....	10
Features & Benefits	11
Specifications.....	12
Protector Combination Glove Boxes Specifications	13
Protector Controlled Atmosphere & Combination Glove Boxes Ordering Information	14
Protector Controlled Atmosphere & Combination Glove Boxes Dimensional Data	15
AtmosPure™ Re-Gen Gas Purifiers	
Introduction.....	16
Specifications & Ordering Information	17
Accessories	18
Protector Controlled Atmosphere & Combination Glove Boxes Accessories	18
General Accessories	21
Base Stands	23
Left Side Door Option	24

Overview

A glove box is a sealed enclosure that allows handling of materials through long, relatively impermeable gloves secured to ports in the walls of the enclosure. The purpose of a glove box is protection or isolation, which is provided by the physical barrier. Depending on the type of glove box, the physical barrier may be to isolate a sensitive material inside the box from environmental contamination or to protect the operator from hazardous materials being manipulated inside the box.

Protector® Glove Boxes—Top of the line protection

With this latest generation of Protector Glove Boxes, Labconco has engineered and manufactured our most leak-tight boxes ever. Fewer leaks mean greater protection to the user and better control of the glove box atmosphere. Protector Glove Boxes are rigorously tested to exacting standards. Every Protector Glove Box is leak tested using a helium mass spectrometer. A test probe checks for the presence of leaks at all joints, seals and seams. Protector Glove Boxes have no detectable leaks greater than 1×10^{-6} ml/second, which calculates to less than 0.09 ml per day.

Labconco's Protector line of glove boxes consists of vented filtered glove boxes, controlled atmosphere glove boxes and combination vented/controlled atmosphere glove boxes. These types of glove boxes are described below.

Protector® Filtered Glove Boxes

These glove boxes have inlet and outlet filters (either HEPA or ULPA) that protect the operator from hazardous particulates and establish a "clean room" environment inside the box. Protector Filtered Glove Boxes are available in three configurations:

- **Single-width HEPA-filtered glove boxes with one-piece molded fiberglass liners**
- **Single-width ULPA-filtered glove boxes with stainless steel liners**
- **Double-width ULPA-filtered glove boxes with stainless steel liners**



Protector Glove Boxes are available in double width suitable for two operators.

Protector® Glove Boxes

INTRODUCTION

Protector® Controlled Atmosphere Glove Boxes

These glove boxes isolate sensitive material inside the box from environmental contamination. Since the materials inside the box are often sensitive to oxygen or moisture, the ambient environment inside the box is replaced with an inert gas such as nitrogen, argon or helium. These glove boxes are sometimes called “dry boxes.” Protector Controlled Atmosphere Glove Boxes are available in the following configurations:

Single-width glove boxes with one-piece molded fiberglass liners

- Basic Models (with manual control)
- Auto Pressure Controller Models

Single-width glove boxes with stainless steel liners

- Basic Models (with manual control)
- Auto Pressure Controller Models

Double-width glove boxes with stainless steel liners

- Basic Models (with manual control)
- Auto Pressure Controller Models



Protector Controlled Atmosphere Glove Boxes create ultra low oxygen and moisture conditions inside the chamber for applications involving sensitive materials.

Protector Combination Glove Boxes

A combination glove box has the capability to function as either a filtered box or a controlled atmosphere glove box. Opening two internal valves converts the box from controlled atmosphere mode to filtered mode. Laboratories that have multiple types of glove box applications or anticipate that their applications may change in the future are ideal users of this type of glove box. All of these glove boxes include an Auto-Pressure Controller. Protector Combination Glove Boxes are available in three configurations:

- **Single-width glove boxes with one-piece molded fiberglass liners and HEPA filters**
- **Single-width glove boxes with stainless steel liners and ULPA filters**
- **Double-width glove boxes with stainless steel liners and ULPA filters**



Protector Combination Glove Boxes have features of both filtered ventilated and controlled atmosphere glove boxes. Two internal valves allow the box to be converted from filtered mode to controlled atmosphere.

Basic Models vs. Auto Pressure Controller Models

To reduce moisture and oxygen levels below 1% in the main chamber requires from 75 to 100 evacuation and fill cycles. An additional 100 cycles further reduce moisture and oxygen levels below 0.3% (3000 ppm). Basic Models with analog gauges and vacuum outlet and gas inlet valves allow the user to manually fill the controlled atmosphere glove box with inert gas and evacuate with a vacuum pump. For infrequent use or for laboratories with a plentiful and inexpensive supply of inert gas, the Basic Model is a viable option. However, this manual process is time consuming and requires constant supervision. Some Protector Controlled Atmosphere Glove Boxes and all Protector Combination Glove Boxes include the Auto-Pressure Controller. Auto-Pressure Controller Models may be programmed to regulate the evacuation and backfill of the glove box, up to 499 times for the main chamber and up to 199 times for the transfer chamber. In addition, the Auto-Pressure Controller monitors and controls glove box pressure. The user establishes an operating pressure range by setting upper and lower pressure limits. Glove box pressure is automatically adjusted as barometric pressure and laboratory temperature change. With the Auto-Pressure Controller, the process is automated so that the glove box may be left unattended during the evacuation and fill cycles.



The Auto Pressure Controller option is available on some models of Protector Controlled Atmosphere Glove Boxes and all models of Protector Combination Glove Boxes.

Protector® Glove Boxes

INTRODUCTION



AtmosPure™ Re-Gen Gas Purifier

The AtmosPure Re-Gen Gas Purifier is an optional accessory that further reduces the oxygen and moisture levels in controlled atmosphere glove boxes below 0.3%. In addition, it saves the time and inert gas expense of repeated evacuating and filling the glove box to maintain the desired atmosphere. The AtmosPure circulates

the established inert atmosphere through copper catalyst and molecular sieve to achieve oxygen and moisture levels below 1 ppm. The chart below shows that after 220 evacuation and filling cycles and 60 minutes, the main chamber of the Protector Stainless Steel Controlled Atmosphere Glove Box was reduced to 653.6 ppm. The AtmosPure Re-Gen Gas Purifier further reduced the oxygen level to 0.7 ppm after 150 minutes (a total of 210 minutes). The large capacity molecular sieve and catalyst require regeneration as little as once every one to three months.

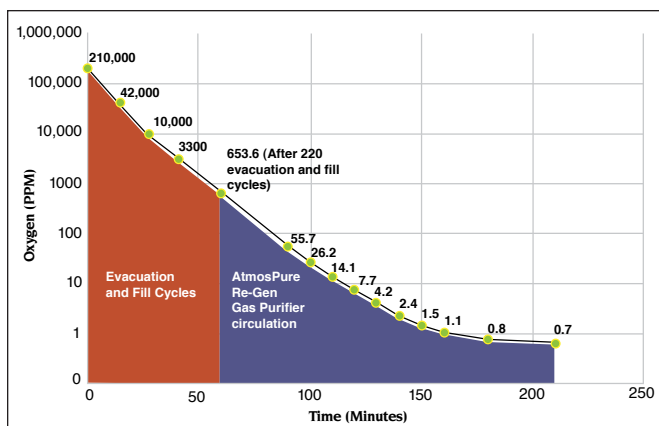

In this test, the AtmosPure Re-Gen Gas Purifier reduced the oxygen level inside the Protector Stainless Steel Controlled Atmosphere Glove Box to 0.7 ppm (0.00007%).

	Protector Fiberglass	Protector Stainless Steel
Attainable Oxygen Purity (ppm)*	0.4 ppm	0.2 ppm
Usable Oxygen Permeation	0.16 ppm/min	0.14 ppm/min
Approximate Oxygen Life (ppm)	13,500 ppm**	13,500 ppm**
Approximate Oxygen Life (days)	58	67

The chart above indicates the capacity of the AtmosPure Re-Gen Gas Purifier before regeneration is required.

Liner Material

Protector Glove Boxes are available in two liner types: one-piece molded fiberglass or stainless steel. Both stainless steel and fiberglass are more impermeable to oxygen and moisture than less favorable materials such as acrylic, polycarbonate and vinyl. Stainless steel is slightly less permeable to oxygen than fiberglass, which may be a consideration in some ultra low oxygen controlled atmosphere applications. Selection between fiberglass and stainless steel, therefore, should be based on personal preference, corrosion-resistance and heat-resistance related to the operator's applications. The chart that follows compares the two liner materials.

*Results were attained at Labconco Corporation under controlled conditions. Actual results may vary.

**Equivalent to 5 liters

Liner Material	Stain Resistance	Moisture Resistance	Chemical Resistance	Heat Resistance	Cleanability	Light Intensity
One-Piece Molded Fiberglass	Good	Excellent	Excellent	Very Good	Excellent (smooth finish)	120 footcandles
Stainless Steel	Good	Excellent	Good resistance to a wide range, Subject to attack by some acids	Excellent	Good	80 footcandles

Particulate containment

Labconco measured the ability of the Protector HEPA-Filtered Glove Box to contain powders. Naproxen sodium, a non-potent active pharmaceutical ingredient, was selected for the study because it is safe to handle, readily detectable in air at very low concentrations, has a high dustiness quotient and challenging electrostatic properties. Three separate operators performed repeated small scale weighing operations and samples were taken from the operator breathing zones, HEPA filter, transfer chamber and room. The samples on filter cassettes were analyzed using high performance liquid chromatography coupled with fluorescence detection capable of detecting as little as two nanograms. SafeBridge Consultants, Incorporated, confirmed the test results: all samples showed particulates below 20 nanograms per cubic meter indicating excellent particulate containment.

Excellent stability

Weighing potent fine powders is a common application for Protector Filtered Glove Boxes. Since analytical balances may be sensitive to motion disturbances, the vibration of the Protector HEPA-Filtered Glove Box was tested at various airflow volumes. Less than 0.38×10^{-5} inches displacement was detected at the center of the work surface.

Airflow Volume (CFM)	Displacement ($\times 10^{-5}$ meters)
15	0.09 to 0.27
28	0.07 to 0.24
39	0.31 to 0.38
54	0.12 to 0.28
65	0.12 to 0.27
78	0.12 to 0.26
84	0.14 to 0.25

The glove box was also tested using a five-place analytical balance placed inside with and without the Balance Vibration Isolator 5234600 (marble slab with stainless steel cover) positioned in the center of the work surface. The glove box was tested at various blower speeds and under typical laboratory



conditions. No efforts were made to isolate the glove box from foot traffic and laboratory equipment operating in the area. Results were excellent. The analytical balance readings remained stable to five decimal places.

Protector HEPA-Filtered Glove Boxes are ideal for containing sensitive balances used in weighing hazardous powders.

Protector® Glove Boxes

SELECTION GUIDE

APPLICATION / MATERIAL	RECOMMENDED GLOVE BOXES	KEY ATTRIBUTES
Work with hazardous airborne particulates or powders <ul style="list-style-type: none"> Pharmaceutical R & D and manufacturing Biochemistry Non-biohazardous microorganisms Particulate chemical carcinogens Asbestos handling Proteins and enzymes Weighing potent fine powders (5441300 Blower Foot Switch recommended) Cleanroom applications with materials sensitive to airborne particulates and requiring ISO Class 3 conditions (5441200 Positive Pressure Conversion Kit required) 	Protector Fiberglass HEPA Filtered Glove Box	Airborne particulate cleanliness <ul style="list-style-type: none"> Exceeds ISO Class 4 Achieves ISO Class 3
	Protector Stainless Steel ULPA Filtered Glove Box	Particulate containment below 20 nanograms/m ³ (naproxen sodium surrogate) ASHRAE 110-1995 tracer gas <0.01 ppm average Low vibration, <0.28 x 10 ⁻⁵ displacement Analytical balance readings to five places
<ul style="list-style-type: none"> Nanoparticle manipulation 	Protector Stainless Steel ULPA Filtered Glove Box Protector Double Stainless Steel ULPA Filtered Glove Box	
Work with contamination-sensitive materials in a controlled environment <ul style="list-style-type: none"> Organometallic chemistry Hydrophilic chemical handling Organic synthesis Electronic component assembly Lithium battery handling Hemoglobin research Metabolic research 	Basic Models Protector Fiberglass Controlled Atmosphere Glove Box with manual control Protector Stainless Steel Controlled Atmosphere Glove Box with manual control Protector Double Stainless Steel Controlled Atmosphere Glove Box with manual control	Manual inert gas filling and vacuum pump evacuation Exceeds Class 1 atmosphere containment per ISO 10648-2 Low oxygen level Low moisture level
	Automatic Pressure Controller Models Protector Fiberglass Controlled Atmosphere Glove Box with auto pressure control Protector Stainless Steel Controlled Atmosphere Glove Box with auto pressure control Protector Double Stainless Steel Controlled Atmosphere Glove Box with auto pressure control	Automatic inert gas filling and vacuum pump evacuation Exceeds Class 1 atmosphere containment per ISO 10648-2 Low oxygen level Low moisture level
	AtmosPure Re-Gen Gas Purifier accessory with any Protector Controlled Atmosphere Glove Box	Manual or automatic inert gas filling and vacuum pump evacuation Exceeds Class 1 atmosphere containment per ISO 10648-2
	Protector Fiberglass Controlled Atmosphere Glove Box with AtmosPure Re-Gen Gas Purifier	Ultra low oxygen level to 0.4 ppm Ultra low moisture level to 2 ppm
	Protector Stainless Steel Controlled Atmosphere Glove Box with AtmosPure Re-Gen Gas Purifier	Ultra low oxygen level to 0.2 ppm Ultra low moisture level to 1 ppm
	Protector Double Stainless Steel Controlled Atmosphere Glove Box with AtmosPure Re-Gen Gas Purifier	Ultra low oxygen level to 0.2 ppm Ultra low moisture level to 1 ppm
Work with hazardous airborne particulates or powders when in filtered glove box mode See specific applications listed above Work with contamination-sensitive materials when in controlled atmosphere glove box mode See specific applications listed above	Protector Fiberglass Combination Glove Box with auto pressure control Protector Stainless Steel Combination Glove Box with auto pressure control Protector Double Stainless Steel Combination Glove Box with auto pressure control	Same Protector Filtered Glove Box attributes listed above Automatic inert gas filling and vacuum pump evacuation Exceeds Class 1 atmosphere containment per ISO 10648-2 Low oxygen level Low moisture level
	AtmosPure Re-Gen Gas Purifier accessory with any Protector Combination Glove Box	Same Protector Filtered Glove Box attributes listed above Automatic inert gas filling and vacuum pump evacuation Exceeds Class 1 atmosphere containment per ISO 10648-2
	Protector Fiberglass Combination Glove Box with AtmosPure Re-Gen Gas Purifier	Ultra low oxygen level to 0.4 ppm Ultra low moisture level to 2 ppm
	Protector Stainless Steel Combination Glove Box with AtmosPure Re-Gen Gas Purifier	Ultra low oxygen level to 0.2 ppm Ultra low moisture level to 1 ppm
	Protector Double Stainless Steel Combination Glove Box with AtmosPure Re-Gen Gas Purifier	Ultra low oxygen level to 0.2 ppm Ultra low moisture level to 1 ppm

Protector® Filtered Glove Boxes

INTRODUCTION

Protector Filtered Glove Boxes are ventilated boxes that use ambient air to provide user protection from extremely hazardous particulates for applications such as nanoparticle manipulation, toxic powder weighing, pharmaceutical research and biochemistry. Microorganisms, low-level radiochemicals, chemical carcinogens and asbestos may also be used in these boxes. In addition,

by reversing the negative air pressure in the main chamber to positive pressure, these boxes may be used for cleanroom applications requiring ISO Class 3 conditions. Models with one-piece molded fiberglass liners feature inlet and outlet HEPA filters. Models with stainless steel liners feature inlet and outlet ULPA filters.

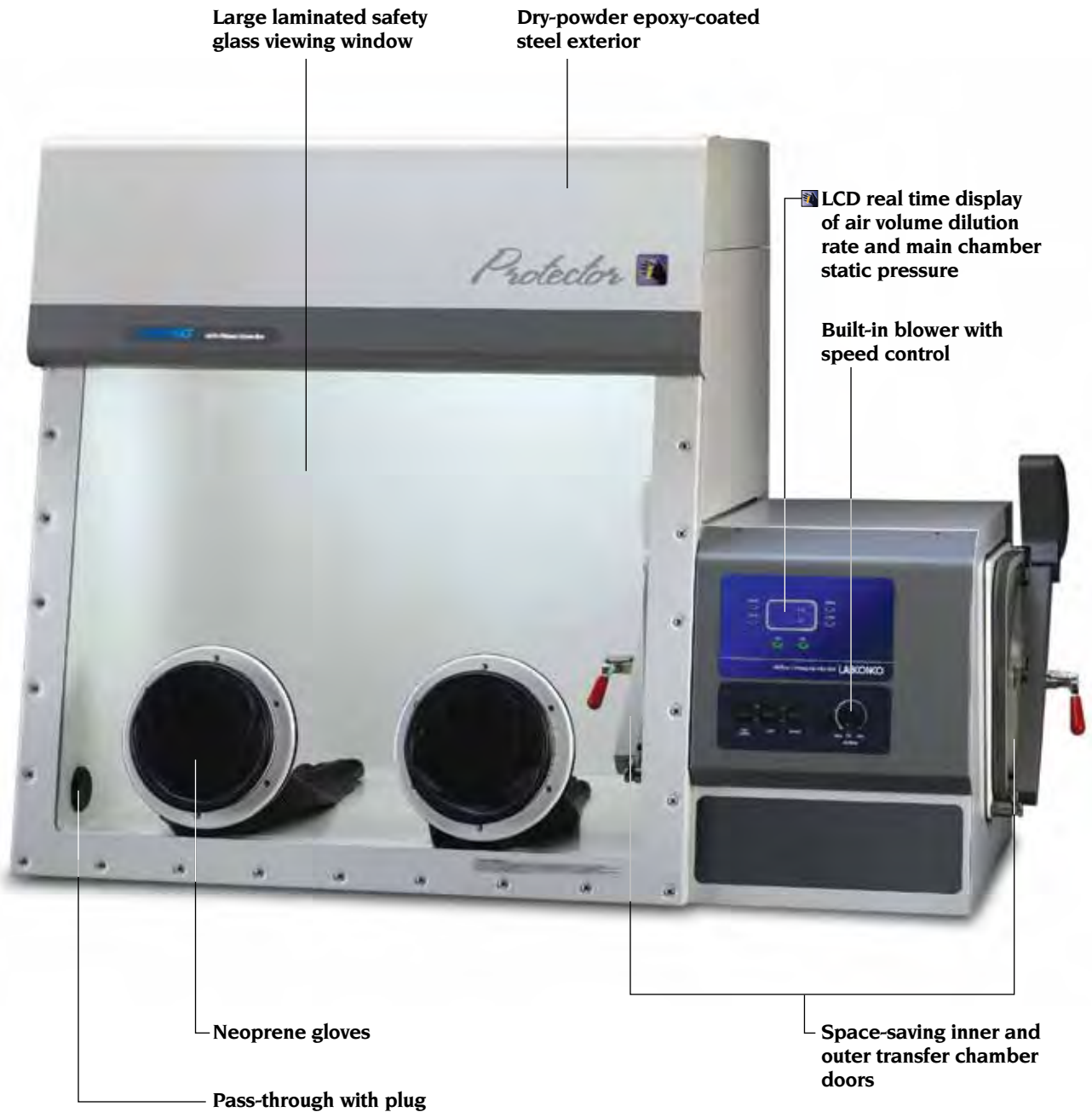

 Exclusive Feature



Protector® Filtered Glove Boxes

FEATURES & BENEFITS

Inlet and outlet HEPA or ULPA filters prevent particulate contaminants from entering or leaving the glove box chamber. HEPA filters, which are standard on fiberglass-lined boxes, are 99.99% efficient on 0.3 micron particulates. ULPA filters, which are standard on stainless steel-lined boxes, are 99.999% efficient on 0.12 particulates.

True Bag-in/Bag-out Filter Disposal System allows for safe filter removal and replacement.

Particulate-free Class 3 conditions. Airborne particulate cleanliness (measured under positive and negative pressures per ISO 14644-1 test method) exceeds ISO Class 4 conditions and achieves ISO Class 3 conditions.

Particulate containment <20 nanograms per cubic meter as confirmed by SafeBridge Consultants, Incorporated assures user protection during glove box use.

Built-in blower with speed control, capable of airflows from 15 to 85 CFM, pulls room air through the inlet HEPA or ULPA filter and discharges HEPA or ULPA filtered air back into the laboratory through the top of the box. This negative pressure operation ensures that all internally-contaminated air passes through the exhaust filter before returning to the laboratory.

Fast “clean up” reduces turnaround time to load and unload materials. During perimeter scan testing, 0.05 ppm average tracer gas levels or less were detected after a five-minute dilution (surpasses ASHRAE 110 standards).

Leak-tight. Each box is factory-tested with a mass spectrometer while pressurized with helium at 5 inches of water gauge and found to have no detectable leaks greater than 1×10^{-6} ml/sec.

LCD display provides real time monitoring and adjustable alarm levels for volume dilution rates in cubic feet per minute (CFM) and air changes/minute (ACM), and main chamber static pressure in inches of water, which indicates HEPA/ULPA filter loading. An audible/visual alarm alerts when airflow/pressure is below set limits.

Bright interior. Fluorescent illumination exceeds 120 foot-candles on fiberglass-lined models and 80 footcandles on stainless steel-lined models.

Interior, left-hand side, wall-mounted pass-through with plug allows for on-site installation of an optional electrical receptacle or optional pass-through port for RS-232, gas/liquid or oxygen or moisture monitor.

Large laminated safety glass viewing window provides maximum visibility (36" wide x 27.7" high) and is removable to allow for placement of large equipment. A powder-coated steel frame and one piece neoprene gasket form a tight seal.

Space-saving inner and outer transfer chamber doors pivot upward to conserve space and are counterbalanced and equipped with quick latches for easy operation.

Interior right-hand side wall-mounted electrical receptacle (duplex on 100/115 volt models, single on 230 volt models), with 10 amp maximum circuit load, provides power for instruments inside box. Double glove boxes also include a centrally-mounted interior receptacle.

Neoprene gloves, size 9 ¾, 30" long, are impermeable to water vapor, gases and toxic chemicals.

Large transfer chamber allows quick transfer of materials and equipment between the laboratory and main chamber.

One-piece molded fiberglass or type 304 stainless steel liner provides a smooth, durable surface that resists chemical corrosion and simplifies cleaning.

Dry-powder epoxy-coated steel exterior, has superior corrosion resistance.

ETL-listed. All North America models carry the ETL mark signifying they are certified to UL 61010-1 and CAN/CSA C22.2 No. 1010.1.

CE mark. All international models conform to the CE (European Community) requirements for electrical safety and electromagnetic compatibility.

Full one-year warranty on parts and labor.



The **Protector Combination Glove Box** functions as a filtered glove box with the added ability to be switched to a controlled atmosphere box as needed. See pages 13-14 for more information.

Protector® Filtered Glove Boxes

SPECIFICATIONS



Protector Filtered Glove Box
5065010 on Adjustable
Height Mobile Base Stand
5235500.



Fiberglass-lined models feature:

- Inlet and outlet HEPA filters, 99.99% efficient on 0.3 micron particulates.
- One-piece molded fiberglass liner.
- Clear acrylic inner and outer transfer chamber doors.

☑ Illumination exceeds 120 footcandles.

Stainless steel-lined models feature:

- Inlet and outlet ULPA filters, 99.999% efficient on 0.12 micron particulates.
- Type 304 stainless steel liner.
- Type 304 stainless steel inner and outer transfer chamber doors.
- Type 304 stainless steel front panel.
- Illumination exceeds 80 footcandles.

Double width models feature:

- Inlet and outlet ULPA filters, 99.999% efficient on 0.12 micron particulates.
- Type 304 stainless steel liner.
- Type 304 stainless steel inner and outer transfer chamber doors.
- Type 304 stainless steel front panel.
- Four fluorescent lights.
- Illumination exceeds 80 footcandles.
- Centrally-mounted electrical receptacle.
- Two viewing windows.
- Four neoprene gloves and glove ports.

All models require:

- Supporting base. Adjustable Height Mobile and Stationary Base Stands are available. See pages 23-24.

Options include:

- Factory installed left side door. See page 24.
- Factory installed valves. Contact Labconco for ordering information.

See pages 9 and 21-24 for ordering information on optional accessories.

See page 8 for dimensional data.

☑ Exclusive Feature *Tested on fiberglass-lined model.

All models feature:

- ☑ Particulate containment <20 nano-grams per cubic meter (naproxen sodium surrogate) as confirmed by SafeBridge Consultants, Incorporated.
- ☑ Fast “clean up” time. 0.05 ppm average tracer gas levels or less detected during perimeter scan testing (surpasses ASHRAE 110 standards) after 5 minute dilution.
- ☑ Airborne particulate cleanliness (measured under positive and negative pressures per ISO 14644-1 test method) exceeds ISO Class 4 conditions and achieves ISO Class 3 conditions.
- ☑ Factory leak-tested with a mass spectrometer while pressurized with helium at 1 inch of water gauge. No detectable leaks greater than 1×10^{-6} ml/sec.
- Inlet and outlet particulate (HEPA or ULPA) filters.
- Test port for challenging HEPA or ULPA filter integrity.
- True Bag-In/Bag-Out Filter Disposal System.
- ☑ LCD display and programmable alarm levels of volume dilution rates in cubic feet per minute (CFM), air changes/minute (ACM), and main chamber pressure (inches of water).
- Mutable, audible/visual low airflow/pressure alarm.
- ☑ Built-in blower with speed control capable of airflow from 15 CFM to 85 CFM depending on voltage and frequency.
- Laminated safety glass, 3/8" thick, viewing window. Viewing area, 36" w x 27.7" high.
- ☑ Inner and outer pivoting transfer chamber doors, counterbalanced and equipped with quick-latches.
- ☑ Interior right-hand side wall-mounted electrical receptacle (duplex on 100/115 volt models) with 10 amp maximum.
- ☑ Interior left-hand side wall-mounted pass-through with plug.
- Pair of neoprene gloves, 0.015" thick, 30" long, size 9 3/4.
- Switches for light, blower and electrical receptacle.
- Two 8" ID, epoxy-coated aluminum, double-grooved glove ports with neoprene gaskets.
- Two 25-watt fluorescent lights.
- Dry-powder epoxy-coated, 18 and 20 gauge steel exterior panels.
- ETL listing, UL 61010-1 and CAN/CSA C22.2 No. 1010.1 conformity (North America models).
- CE Conformity Marking (International models).

Protector® Filtered Glove Boxes

ORDERING INFORMATION

Use this key to configure the **seven digit catalog number** to order your Protector Filtered Glove Box. For example, a **5065010** is a Protector HEPA-Filtered Glove Box with fiberglass liner and North America, 100-115 volts receptacle and plug type.

Configure Your Catalog Number:

5 0 6 5 0 1 0

The first five digits indicate liner material and filter type.

The last two digits indicate receptacle and plug type and glove box width.

Step 1. Choose one of two liner/filter options:

Option 1:

Fiberglass-lined, HEPA filtration. The first five digits are **50650**.

Option 2:

Stainless steel-lined, ULPA filtration. The first five digits are **50655**.

Step 2.

Select your Receptacle and Plug Type and Glove Box Width.

Option 1: North America, 100-115 volts. The last two digits are **10** for single width, **12** for double width.

Option 2: British (UK). The last two digits are **31** for single width, **33** for double width.

Option 3: Schuko. The last two digits are **35** for single width, **37** for double width.

Option 4: China/Australia. The last two digits are **40** for single width, **42** for double width.

Option 5: North America, 208-230 volts. The last two digits are **45** for single width, **47** for double width.

Base Catalog Number	Glove Box Width	Filter Type	Liner Material	Shipping Weight lbs./kg	Electrical Receptacle & Plug Type				
					North America 115 Volts	British (UK)*	Schuko*	China/Australia*	North America 230 Volts
50650	Single	HEPA	Fiberglass	500/227	10	31	35	40	45
50655	Single	ULPA	Stainless Steel	650/295	10	31	35	40	45
50655	Double	ULPA	Stainless Steel	1300/590	12	33	37	42	47

*International electrical configuration

Electrical Receptacle & Plug Configurations & Electrical Requirements

North America, 110-115 volts

100-115 volts, 50/60 Hz, 10 amps

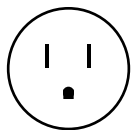

For Catalog Numbers ending in 10 or 12



British (UK)

208-230 volts, 50/60 Hz, 10 amps

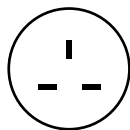

For Catalog Numbers ending in 31 or 33



Schuko

208-230 volts, 50/60 Hz, 10 amps

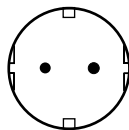

For Catalog Numbers ending in 35 or 37



China/Australia

208-230 volts, 50/60 Hz, 10 amps

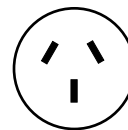

For Catalog Numbers ending in 40 or 42



North America, 208-230 volts

208-230 volts, 60 Hz, 10 amps

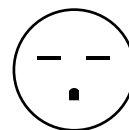

For Catalog Numbers ending in 45 or 47



Built-in Blower Information (115 volt, HEPA-filtered models)**

% Blower Speed Control Setting	Air Volume Changes Per Minute (ACM)	Exhaust Volume (CFM)	Noise Pressure db(A)	Static Pressure in Glove Box (in. of H ₂ O)	Total System Static Pressure (in. of H ₂ O)
Min. 18%	0.9	15	52	0.12	0.31
35%	1.8	30	54	0.30	0.62
55%	2.8	48	59	0.54	1.14
75%	3.8	65	63	0.87	1.65
100%	5.0	85	68	1.28	2.48

**Contact Labconco for blower information on other models.

Protector® Filtered Glove Boxes

DIMENSIONAL DATA

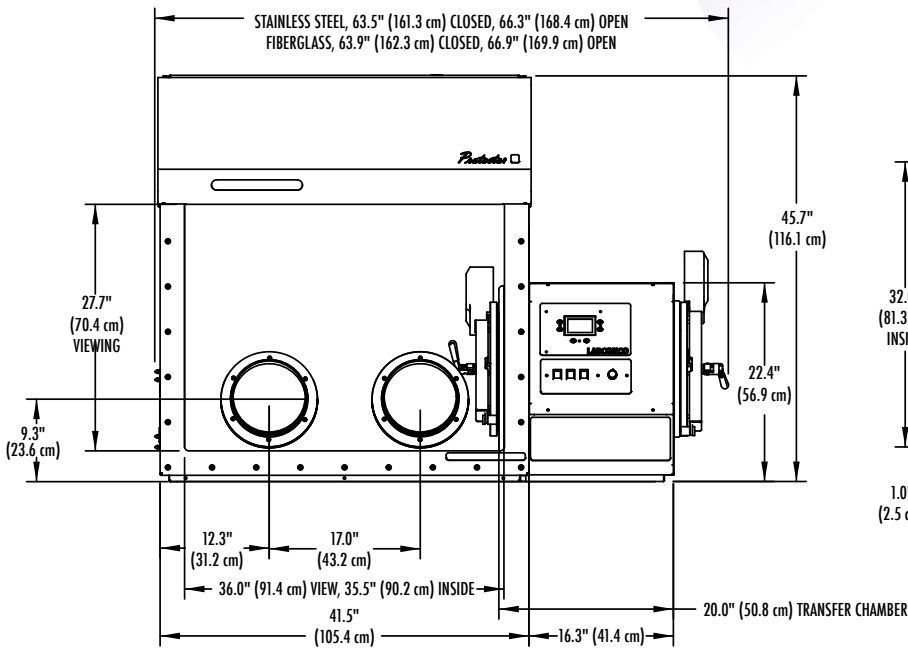

FRONT VIEW—SINGLE WIDTH MODELS

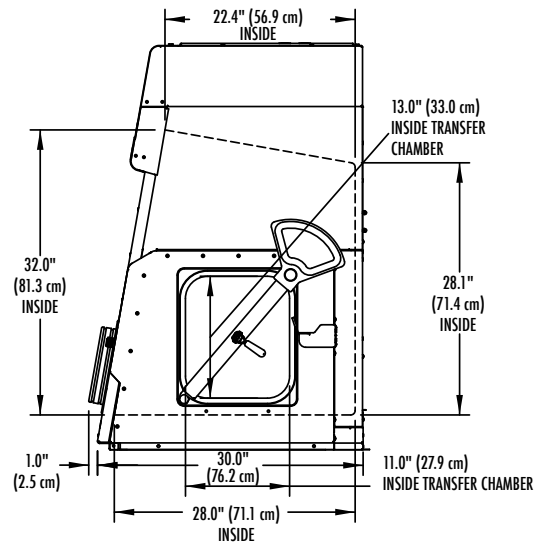

SIDE VIEW—ALL MODELS

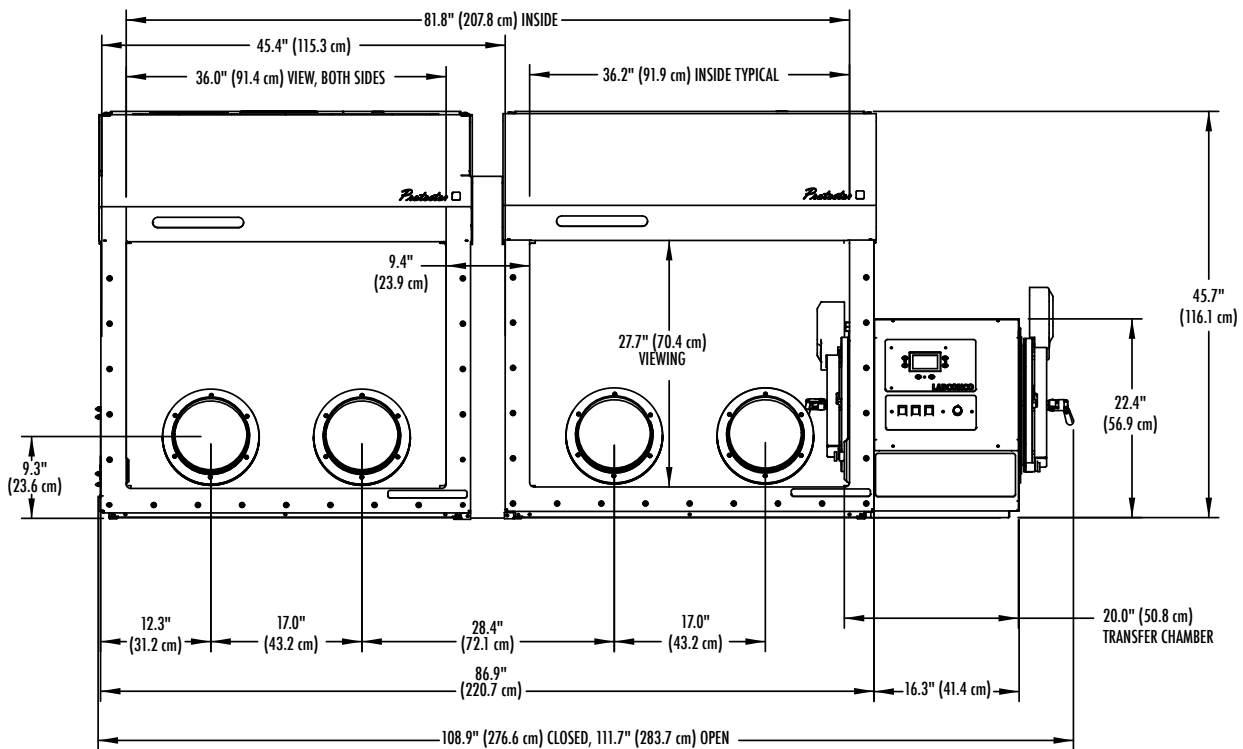

FRONT VIEW—DOUBLE WIDTH MODELS

Protector® Filtered & Combination Glove Boxes

ACCESSORIES



5225105 Replacement Inlet or Outlet HEPA Filter

99.99% efficient on 0.3 micron diameter particles. May also be used in place of standard inlet or outlet ULPA filter. Shipping weight 6.5 lbs. (3 kg)

5225106 Replacement Inlet or Outlet ULPA Filter

99.999% efficient on 0.12 micron diameter particles. May also be used in place of standard inlet or outlet HEPA filter. Shipping weight 6.5 lbs. (3 kg)

5241700 Bag Set for Bag-In/Bag-Out HEPA Filter Replacement

Includes two bags and two straps necessary for changing and disposing of one inlet or outlet filter. Shipping weight 1 lb. (0.5 kg)

5441200 Positive Pressure Conversion Kit

Changes the built-in blower operation from standard negative pressure to positive pressure operation. The blower pushes instead of pulls HEPA/ ULPA filtered air through the main chamber. Typical applications for positive pressure operation include handling materials that are highly sensitive to airborne particulate contaminants. The Positive Pressure Conversion Kit creates particulate cleanliness inside the box measured to ISO 14644-1 test method, achieving ISO Class 3 conditions (1 particle 0.5 µm or larger per cubic foot of air per minute). Includes hose, two clamps and harness assembly. Not recommended for use with applications involving hazardous substances. Shipping weight 6 lbs. (3 kg)

5441100 Recirculation Kit

Allows the built-in blower exhaust to be connected to the inlet HEPA/ ULPA filter, providing total recirculation of air volume useful for semi-dry atmosphere operations. Includes hose, clamps and epoxy-coated steel adapter. Other accessories, such as Valves, Traps and Diaphragm Pumps, may be combined with the Recirculation Kit to maintain specific air chemistry conditions inside the main chamber. See page 20 for ordering information on Drying Train accessories. Shipping weight 5.5 lbs. (2.5 kg)

5242400 DOP Test Kit for HEPA Filters

Includes the connections, hoses and test procedure necessary to conduct a HEPA filter leak test on both the inlet and outlet filter. Test should be performed by a qualified technician using calibrated equipment. Shipping weight 5 lbs. (2 kg)



Add-A-Valve Kits

Include two manual valves, tubes, nuts and instructions to add valves to the glove box for evacuating with vacuum, filling

with inert gas, connecting to a drying train or connecting to filtration components. Valves mount in predrilled holes behind the label located below the control panel.

Catalog Number	Description	Shipping Weight
5442600	Two Manual Valves for Transfer Chamber	5 lbs. (2.2 kg)
5442700	Two Manual Valves for Main Chamber	5 lbs. (2.2 kg)



5441300 Blower Foot Switch

Provides a hands-free means to temporarily shut off power to the blower when obtaining sensitive balance readings or manipulating fine powders. Includes foot pedal and power cord. Shipping weight 4.5 lbs. (2 kg)

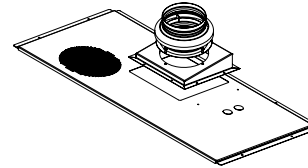

Thimble Exhaust Connectors

Epoxy-coated steel for connecting the glove box to ductwork attached to building exhaust, remote blower or FilterMate

Portable Exhauster. Contact Labconco for ordering information on the FilterMate Portable Exhauster.

Catalog Number	Description	Shipping Weight
5441000	5" diameter. For connection to FilterMate Portable Exhauster.	15 lbs. (6.8 kg)
5440900	6" diameter. For connection to house exhaust or remote blower.	15 lbs. (6.8 kg)

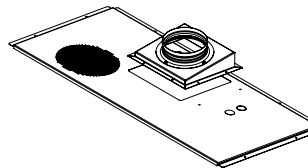

5440800 Hard Duct Connector

Epoxy-coated steel, 6" diameter, for connecting the glove box to ductwork attached to a remote blower. Remote blower must be balanced with glove box's built-in blower.

Requires ductwork and remote blower. Shipping weight 15 lbs. (6.8 kg)



Remote Blowers

For ducting Protector Filtered Glove Boxes. Direct drive blower has a 1/4 hp TEFC-type motor and overcomes external static pressure of 0.5" at 420 CFM. Housing and impeller are corrosion-resistant, phenolic-coated steel. Blower inlet is 5.94" OD and is

sized to accept 6" nominal diameter PVC duct. Blower outlet is 4.25" x 7.38" OD. Dimensions: 14.6" w x 13.5" d x 13.25" high (37.1 x 34.3 x 33.7 cm). **Damper is required.**

CFM @ Static Pressure – Inches of H ₂ O						
S.P.	0.0"	0.125"	0.25"	0.50"	0.75"	0.87"
CFM	595	560	515	420	300	167

Remote Blowers

Catalog Number	Electrical Requirements	Shipping Weight
4863500	115 volts, 60 Hz, 4.4 amps	35 lbs. (16 kg)
4863501*	115/230 volts, 50 Hz, 5.6/2.8 amps	35 lbs. (16 kg)

*International electrical configuration

Dampers

Catalog Number	Description	Shipping Weight
4724200	6" diameter, PVC	1 lb. (0.5 kg)
3924000	6" diameter, Powder-coated steel	1 lb. (0.5 kg)

Protector® Controlled Atmosphere Glove Boxes

INTRODUCTION

Protector Controlled Atmosphere Glove Boxes provide a leak-tight environment for work with contamination-sensitive materials. Organometallic chemistry, lithium battery handling, hemoglobin research and other procedures using oxygen- or moisture-sensitive materials may be performed in these boxes.

Stainless steel-lined glove boxes have ultralow oxygen permeation rates (<0.16 ppm/min) while fiberglass-lined models have rates as low as <0.3 ppm/min, both achieving Class I atmosphere conditions. On Auto Pressure Controller models, the evacuation and filling cycles may be automated and monitored.



Exclusive Feature



Protector® Controlled Atmosphere Glove Boxes

FEATURES & BENEFITS

Leak-tight. Each box is factory-tested with a mass spectrometer while pressurized with helium at 5 inches of water gauge and found to have no detectable leaks greater than 1×10^{-6} ml/sec.

Low oxygen and moisture levels maintained*. Fiberglass models maintained oxygen levels as low as 0.4 ppm and moisture levels as low as 2 ppm. Stainless steel models maintained oxygen levels as low as 0.2 ppm and moisture levels as low as 1 ppm.

Exceed Class I atmosphere containment conditions for low oxygen permeation per ISO 10648-2. Fiberglass models achieve <0.3 ppm/min. Stainless steel models achieve the lowest permeation at <0.16 ppm/min.

Four inlet/outlet valves, two on the main chamber and two on the transfer chamber, allow for evacuating and filling the chambers via an accessory vacuum pump and inert gas.

■ **Two 3/4" OD rear-mounted inlet and outlet compression fittings** allow for easy connection to optional AtmosPure Re-Gen Gas Purifier or other accessory drying train.

■ **Auto pressure controller,** on models without analog gauges, provides monitor and control of the main chamber pressure, main chamber evacuation and filling cycles (up to 499) and transfer chamber evacuation and filling cycles (up to 199).

- The controller regulates vacuum/pressure between -5 and +5 water gauge in the main chamber and between 0 and -29.5 inches mercury in the transfer chamber.
- An audible alarm sounds when pressure/vacuum level is outside set limits.
- The LCD displays main and transfer chamber pressure.
- Three-position foot pedal provides hands-free control: increase gas/fill, off, and evacuate/decrease gas.
- Input/output port provides connection to optional AtmosPure Re-Gen Gas Purifier.

Main and transfer chamber analog pressure gauges, on models without auto pressure controller, provide a means to monitor pressure levels inside the box.

■ **Factory-installed, rear-mounted, low profile stainless steel pressure relief bubbler** helps to protect against over or under pressurization. Pressure is maintained between -6 and +6 inches water gauge.

■ **Bright interior.** Fluorescent illumination exceeds 120 footcandles on fiberglass-lined models and 80 footcandles on stainless steel-lined models.

■ **Interior, left-hand side, wall-mounted pass-through with plug** allows for on-site installation of an optional electrical receptacle or optional pass-through port for RS-232, gas/liquid or oxygen or moisture monitor.

■ Exclusive Feature

Large laminated safety glass viewing window provides maximum visibility (36" wide x 27.7" high) and is removable to allow for placement of large equipment. A powder-coated steel frame and neoprene gasket form a tight seal.

Space-saving inner and outer transfer chamber doors pivot upward to conserve space and are counterbalanced and equipped with quick latches for easy operation.

Interior right-hand side wall-mounted electrical receptacle (duplex on 100/115 volt models, single on 230 volt models), with 10 amp maximum circuit load, provides power for instruments inside box. Double glove boxes also include a centrally-mounted interior receptacle.

Neoprene gloves, size 9 ¾, 30" long, are impermeable to water vapor, gases and toxic chemicals.

Large transfer chamber allows quick transfer of materials and equipment between the laboratory and main chamber.

■ **One-piece molded fiberglass or type 304 stainless steel liner** provides a smooth, durable surface that resists chemical corrosion and simplifies cleaning.

Dry-powder epoxy-coated steel exterior has superior corrosion resistance.

ETL-listed. All North America models carry the ETL mark signifying they are certified to UL 61010-1 and CAN/CSA C22.2 No. 1010.1.

CE mark. All international models conform to the CE (European Community) requirements for electrical safety and electromagnetic compatibility.

Full one-year warranty on parts and labor.

Optional AtmosPure Re-Gen Gas Purifier, sold separately, maintains low oxygen/moisture atmosphere by circulating the glove box's gas through an oxygen/moisture scavenger that can be regenerated with a reducing gas and heat cycle. See pages 16-18 for more information.



The **Protector Combination Glove Box functions** as a controlled atmosphere glove box with the added ability to be switched to a filtered box as needed. See pages 13-14 for more information.

*Oxygen and moisture levels were achieved using the accessory AtmosPure Re-Gen Gas Purifier. See pages 16-18 for more information.

Protector® Controlled Atmosphere Glove Boxes

SPECIFICATIONS



Protector Controlled Atmosphere Glove Box 5080110 on Adjustable Height Mobile Base Stand 5235500.



- Oxygen permeation <math><0.16\text{ ppm/min per ISO 10648-2}</math>.
- Illumination exceeds 80 footcandles.

Basic Models also feature:

- Main chamber pressure analog gauge with readings from -5 to +5 inches of water gauge.
- Transfer chamber pressure analog gauge with readings from 0 to -29.5 inches of mercury.

Auto Pressure Controller Models also feature:

- Automatic control of the main chamber pressure (-5 to +5 inches of water gauge), main chamber evacuation and filling cycles (up to 499 cycles), and transfer chamber evacuation and filling cycles (up to 199 cycles).
- Regulation of vacuum/pressure between -5 and +5 inches of water gauge in the main chamber and between 0 and -29.5 inches of mercury in the transfer chamber.
- Mutable, audible/visual alarm that sounds when pressure/vacuum level is outside set limits.
- LCD display of main chamber and transfer chamber pressure in inches of water, inches of mercury and mBar.
- Three-position foot pedal (increase gas/fill, off, evacuate/decrease gas).

- Input/output port for optional AtmosPure™ Re-Gen Gas Purifier.

Double width models feature:

- Type 304 stainless steel liner.
- Type 304 stainless steel inner and outer transfer chamber doors.
- Type 304 stainless steel front panel.
- Four fluorescent lights.
- Illumination exceeds 80 footcandles.
- Centrally-mounted electrical receptacle.
- Two viewing windows.
- Four neoprene gloves and glove ports.

All models require:

- Supporting base. Adjustable Height Mobile and Stationary Base Stands are available. See pages 23-24.
- Vacuum pump for evacuating. Rotary Vane Vacuum Pumps are available. See page 19.
- Inert gas for filling. Contact your laboratory supply distributor.

Options include:

- Factory installed left side door. See page 24.

See pages 18-22 for ordering information on optional accessories. See pages 16-18 for ordering information on the AtmosPure Re-Gen Gas Purifier.

See page 15 for dimensional data.

All models feature:

- Factory leak-tested with a mass spectrometer while pressurized with helium at 5 inches of water gauge. No detectable leaks greater than 1×10^{-6} ml/sec.
- Exceed Class 1 atmosphere containment conditions for oxygen permeation <math><1.67\text{ ppm/min per ISO 10648-2 test method}</math>.
- Laminated safety glass, 3/8" thick, viewing window. Viewing area, 36" w x 27.7" high (91 x 70 cm).
- Inner and outer pivoting transfer chamber doors, counterbalanced and equipped with quick-latches.
- Four manual valves with 3/8" compression fittings—two on the main chamber and two on the transfer chamber.
- Factory-installed, rear-mounted stainless steel pressure relief bubbler at ± 6 inches of water gauge.
- Two rear-mounted inlet and outlet 3/4" OD compression fittings for connection to optional AtmosPure™ Re-Gen Gas Purifier or other accessory drying train.
- Interior right-hand side wall-mounted electrical receptacle (duplex on 100/115 volt models) with 10 amp maximum.
- Interior left-hand side wall-mounted pass-through with plug.
- Pair of neoprene gloves, 0.015" thick, 30" long, size 9¾.
- Switches for light and electrical receptacle.

Exclusive Feature

- Two 8" ID, epoxy-coated aluminum, double-grooved glove ports with neoprene gaskets.
- Two 25-watt fluorescent lights.
- Dry-powder epoxy-coated, 18 and 20 gauge steel exterior panels.
- ETL listing, UL 61010-1 and CAN/CSA C22.2 No. 1010.1 conformity (North America models).
- CE Conformity Marking (International models).

Fiberglass-lined models feature:

- One-piece molded fiberglass liner with clear acrylic inner and outer transfer chamber doors.
- Performance tested to maintain oxygen levels as low as 0.4 ppm and moisture levels as low as 2 ppm.
- Oxygen permeation <math><0.3\text{ ppm/min per ISO 10648-2}</math>.
- Illumination exceeds 120 footcandles.

Stainless steel-lined models feature:

- Type 304 stainless steel liner with Type 304 stainless steel inner and outer transfer chamber doors. Type 304 stainless steel front panel.
- Performance tested to maintain oxygen levels as low as 0.2 ppm and moisture levels as low as 1 ppm.

Protector® Combination Glove Boxes

SPECIFICATIONS



Protector Combination Glove Box 5080060 on Adjustable Height Mobile Base Stand 5235500.

All models feature:

- Factory leak-tested with a mass spectrometer while pressurized with helium at 5 inches of water gauge. No detectable leaks greater than 1×10^{-6} ml/sec.
- LCD dual display. One regulates and displays pressure of both chambers. The second displays airflow (CFM), air changes/minute (ACM), and main chamber pressure (inches of water).
- Laminated safety glass, 3/8" thick, viewing window. Viewing area: 36.0" w x 27.6" high (91 x 70 cm).
- Inner and outer pivoting transfer chamber doors, counterbalanced and equipped with quick-latches.
- Interior right-hand side wall-mounted electrical receptacle (duplex on 100/115 volt models) with 10 amp maximum.
- Interior left-hand side wall-mounted pass-through with plug.
- Two internal valves to convert the glove box from a flow-through filtered box to an inert atmosphere glove box.
- Pair of neoprene gloves, 0.015" thick, 30" long, size 9 3/4.
- Switches for light, blower and electrical receptacle.
- Two 8" ID, epoxy-coated aluminum, double-grooved glove ports with neoprene gaskets.
- Two 25-watt fluorescent lights.
- Dry-powder epoxy-coated, 18 and 20 gauge steel exterior panels.
- ETL listing, UL 61010-1 and CAN/CSA C22.2 No. 1010.1 conformity (North America models).
- CE Conformity Marking (International models).

Filtered glove box features:

- Particulate containment <20 nano-grams per cubic meter (naproxen sodium surrogate) as confirmed by SafeBridge Consultants, Incorporated.
- Fast "clean up" time. 0.05 ppm average tracer gas levels or less detected during perimeter scan testing (surpasses ASHRAE 110 standards) after 5 minute dilution.
- Airborne particulate cleanliness (measured under positive and negative pressures per ISO 14644-1 test method) exceeds ISO Class 4 conditions and achieves ISO Class 3 conditions.
- Inlet and outlet particulate (HEPA or ULPA) filters to prevent contaminants from entering or leaving the glove box chamber.
- Test port for challenging HEPA or ULPA filter integrity.
- True Bag-In/Bag-Out Filter Disposal System for safe filter removal and replacement.
- Built-in blower with speed control capable of airflow from 15 CFM to 85 CFM depending on voltage and frequency.
- Mutable, audible/visual low airflow/pressure alarm.

Controlled atmosphere glove box features:

- Exceed Class 1 atmosphere containment conditions for oxygen permeation <1.67 ppm/min per ISO 10648-2 test method.
- Four manual valves with 3/8" compression fittings—two on the main chamber and two on the transfer chamber.
- Automatic control of the main chamber pressure (-5 to +5 inches of water gauge), main chamber evacuation and filling cycles (up to 499 cycles), and transfer chamber evacuation and filling cycles (up to 199 cycles).
- Regulation of vacuum/pressure between -5 and +5 inches of water gauge in the main chamber and between 0 and -29.5 inches of mercury in the transfer chamber.
- Mutable, audible/visual alarm that sounds when pressure/vacuum level is outside set limits.
- Three-position foot pedal (increase gas/fill, off, evacuate/decrease gas).
- Input/output port for optional AtmosPure™ Re-Gen Gas Purifier.
- Factory-installed, rear-mounted, low profile stainless steel pressure relief bubbler at ± 6 inches of water gauge.
- Two rear-mounted inlet and outlet 3/4" OD compression fittings for easy connection to optional AtmosPure™ Re-Gen Gas Purifier or other accessory drying train.

Fiberglass-lined models feature:

- Inlet and outlet HEPA filters, 99.99% efficient on 0.3 micron particulates.
- One-piece molded fiberglass liner with clear acrylic inner and outer transfer chamber doors.
- Performance tested to maintain oxygen levels as low as 0.4 ppm and moisture levels as low as 2 ppm.
- Oxygen permeation <0.3 ppm/min per ISO 10648-2.
- Illumination exceeds 120 footcandles.

Stainless steel-lined models feature:

- Inlet and outlet ULPA filters, 99.999% efficient on 0.12 micron particulates.
- Type 304 stainless steel liner with Type 304 stainless steel inner and outer transfer chamber doors. Type 304 stainless steel front panel.
- Performance tested to maintain oxygen levels as low as 0.2 ppm and moisture levels as low as 1 ppm.
- Oxygen permeation <0.16 ppm/min per ISO 10648-2.
- Illumination exceeds 80 footcandles.

Double width models feature:

- Inlet and outlet ULPA filters, 99.999% efficient on 0.12 micron particulates.
- Type 304 stainless steel liner.
- Type 304 stainless steel inner and outer transfer chamber doors.
- Type 304 stainless steel front panel.
- Four fluorescent lights.
- Illumination exceeds 80 footcandles.
- Centrally-mounted electrical receptacle.
- Two viewing windows.
- Four neoprene gloves and glove ports.

All models require:

- Supporting base. Adjustable Height Mobile and Stationary Base Stands are available. See pages 23-24.
- Vacuum pump for evacuating. Rotary Vane Vacuum Pumps are available. See page 19.
- Inert gas for filling. Contact your laboratory supply distributor.

Options include:

- Factory installed left side door. See page 24.

See pages 9 and 18-22 for ordering information on optional accessories. See pages 16-18 for ordering information on the AtmosPure Re-Gen Gas Purifier.

See page 15 for dimensional data.

■ Exclusive Feature

Protector® Controlled Atmosphere & Combination Glove Boxes

ORDERING INFORMATION

Use this key to configure the **seven digit catalog number** to order your Protector Controlled Atmosphere or Combination Glove Box. For example, a **5080110** is a Protector Controlled Glove Box with Automatic Pressure Control, stainless steel liner and North America, 100-115 volts receptacle and plug type.

Configure Your Protector Controlled Atmosphere or Combination Glove Box Catalog Number:

5 0 8 0 1 1 0

The first four digits indicate operation type.

The last two digits indicate receptacle and plug type.

The fifth digit indicates liner type.

Step 1. Choose one of two options:

Option 1:

Manual valve operation. The first four digits are **5060**.

Option 2:

Auto Pressure Control operation. The first four digits are **5080**.

Step 2. Choose one of two options:

Option 1:

Fiberglass lined. The fifth digit is **0**.

Option 2:

Stainless steel lined. The fifth digit is **1**.

Step 3.

Select your Receptacle and Plug Type.

Option 1: North America, 100-115 volts. The last two digits are **10** for single width controlled atmosphere, **12** for double width controlled atmosphere, **60** for single width combination, **62** for double width combination.

Option 2: British (UK). The last two digits are **31** for single width controlled atmosphere, **33** for double width controlled atmosphere, **65** for single width combination, **67** for double width combination.

Option 3: Schuko. The last two digits are **35** for single width controlled atmosphere, **37** for double width controlled atmosphere, **70** for single width combination, **72** for double width combination.

Option 4: China/Australia. The last two digits are **40** for single width controlled atmosphere, **42** for double width controlled atmosphere, **75** for single width combination, **77** for double width combination.

Option 5: North America, 208-230 volts. The last two digits are **45** for single width controlled atmosphere, **47** for double width controlled atmosphere, **80** for single width combination, **82** for double width combination.

Protector Controlled Atmosphere Glove Boxes

Base Catalog Number	Glove Box Width	Operation Type	Liner Material	Shipping Weight lbs./kg	Electrical Receptacle & Plug Type				
					North America 115 Volts	British (UK)*	Schuko*	China/Australia*	North America 230 Volts
50600	Single	Manual	Fiberglass	500/227	10	31	35	40	45
50601	Single	Manual	Stainless Steel	650/295	10	31	35	40	45
50601	Double	Manual	Stainless Steel	1300/590	12	33	37	42	47
50800	Single	Auto	Fiberglass	500/227	10	31	35	40	45
50801	Single	Auto	Stainless Steel	650/295	10	31	35	40	45
50801	Double	Auto	Stainless Steel	1300/590	12	33	37	42	47

*International electrical configuration

Protector Combination Glove Boxes

Base Catalog Number	Glove Box Width	Filter Type	Liner Material	Shipping Weight lbs./kg	Electrical Receptacle & Plug Type				
					North America 115 Volts	British (UK)*	Schuko*	China/Australia*	North America 230 Volts
50800	Single	HEPA	Fiberglass	500/227	60	65	70	75	80
50801	Single	ULPA	Stainless Steel	650/295	60	65	70	75	80
50801	Double	ULPA	Stainless Steel	1300/590	62	67	72	77	82

*International electrical configuration

Electrical Receptacle & Plug Configurations & Electrical Requirements

North America, 110-115 volts

100-115 volts, 50/60 Hz, 10 amps

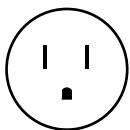

For Catalog Numbers ending in 10, 12, 60 or 62



British (UK)

208-230 volts, 50/60 Hz, 10 amps

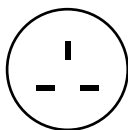

For Catalog Numbers ending in 31, 33, 65 or 67



Schuko

208-230 volts, 50/60 Hz, 10 amps

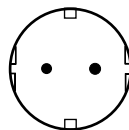

For Catalog Numbers ending in 35, 37, 70 or 72



China/Australia

208-230 volts, 50/60 Hz, 10 amps

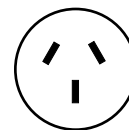

For Catalog Numbers ending in 40, 42, 75 or 77



North America, 208-230 volts

208-230 volts, 60 Hz, 10 amps

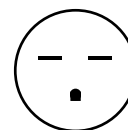

For Catalog Numbers ending in 45, 47, 80 or 82



Protector® Controlled Atmosphere & Combination Glove Boxes

DIMENSIONAL DATA

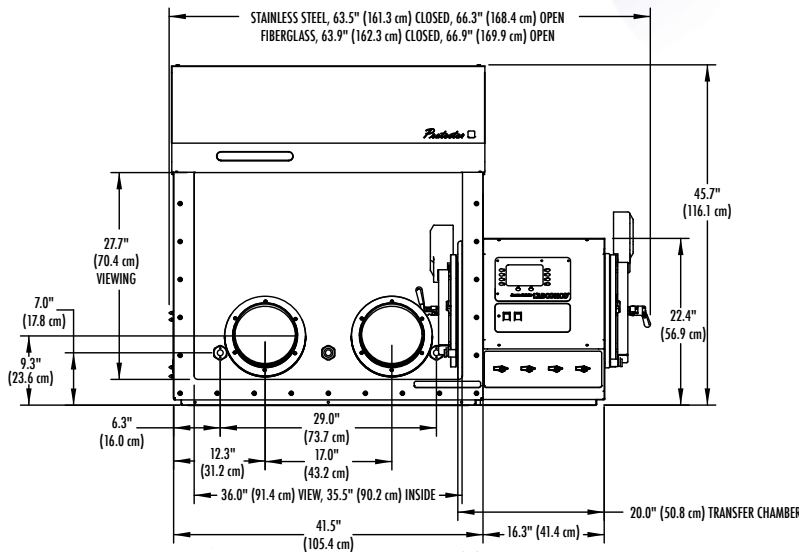

FRONT VIEW—SINGLE WIDTH MODELS

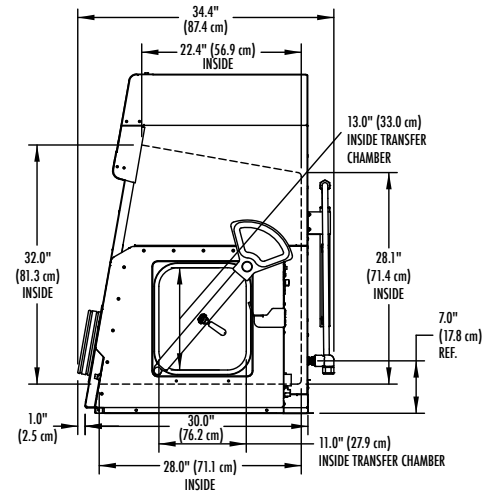

SIDE VIEW—ALL MODELS

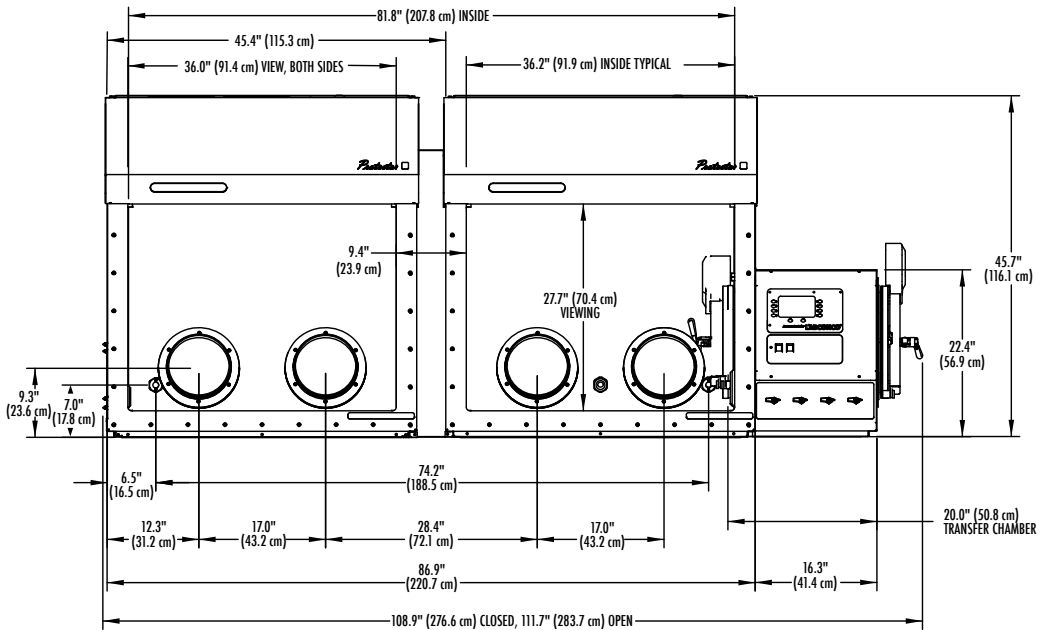

FRONT VIEW—DOUBLE WIDTH MODELS

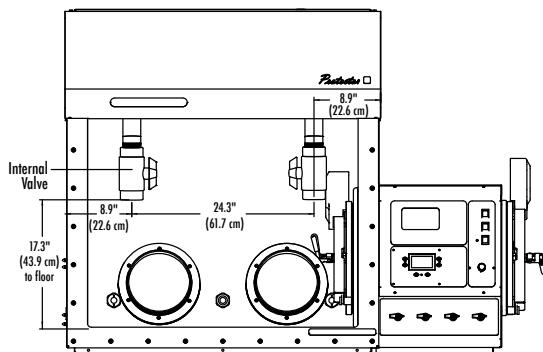

FRONT VIEW

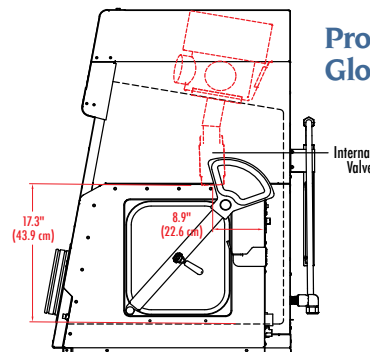

SIDE VIEW

Protector Combination Glove Box Detail

AtmosPure™ Re-Gen Gas Purifiers

INTRODUCTION

The AtmosPure Re-Gen Gas Purifier produces an ultrapure inert atmosphere inside a controlled atmosphere glove box for materials sensitive to moisture and/or oxygen. It circulates an inert gas in the glove box, removing oxygen and moisture. Compatible with any Protector® or Precise® Controlled Atmosphere Glove Box, the AtmosPure allows these glove boxes to meet or exceed ISO 10648-2 test

methods. The Purifier has the capacity to remove up to five liters of oxygen (13,500 ppm) and 660 grams of moisture (18 million ppm) at standard temperature and pressure (STP). Depending on the application, glove box liner material and frequency of use, regeneration may be necessary only once every one to three months and completed in only 13 hours.

Indicator lights show each step of the 13 hour regeneration process. Once complete, regeneration may only be needed again every one to three months.

Start/stop button initiates and ends the regeneration process.

Indicator lights show isolation valve status (closed/open).

Blower button toggles circulation air purifier blower between ON, OFF and AUTO. Indicator lights show status.

Connections for glove box, vacuum pump and gas mixture are easily accessible from the back of the Purifier.



Vacuum release button may be used, if desired, to momentarily release vacuum after regeneration is complete.

Main Power On/Off switch

Two 3/4" manually-operated ball valves isolate the AtmosPure from the glove box during regeneration.

Flow control valve sets the 4% hydrogen/inert gas mixture flow rate from 10 to 25 CFH during regeneration.

Tests show that ultra low oxygen and moisture levels are attainable with the AtmosPure Re-Gen Gas Purifier.	Gas Permeant	Controlled Atmosphere Glove Box Type/Liner Material		
		Protector/ Stainless Steel	Protector/ Fiberglass	Precise/ Polyethylene
Attainable Purity (ppm)*	O ₂	0.2	0.4	3.5
	H ₂ O	1	2	5
Oxygen Permeation at -4" w.g. per ISO 10648-2 Test Method (ppm/min)	O ₂	0.16	0.30	0.60
ISO 10648-2 Acceptance Level for Class I Controlled Atmosphere Glove Boxes (ppm/min)	O ₂	<1.67	<1.67	<1.67
Normal Permeation with Pressure from -1" w.g. to +1" w.g. (ppm/min)	O ₂	0.14	0.16	0.33
	H ₂ O	0.10	0.17	0.21

*Results were attained at Labconco Corporation under controlled conditions. Actual results may vary.

AtmosPure™ Re-Gen Gas Purifiers

SPECIFICATIONS & ORDERING INFORMATION

All models feature:

- ✎ Automatic regeneration process may be completed in as little as 13 hours and while unattended.
- Internal cylinder contains 5 pounds of copper catalyst capable of removing up to 5 liters of oxygen (13,500 ppm) and 5 pounds of molecular sieve capable of removing 660 grams of moisture (18 million ppm) with normal oxygen and moisture permeation rates 0.3 ppm/min or lower.
- ✎ Fully factory-regenerated cylinder is ready to use. Isolation valves arrive closed to maintain molecular sieve and copper catalyst capacity.
- From a 1000 ppm starting condition, able to reduce oxygen to 1 ppm in less than 2 hours.*
 - From a 1000 ppm starting condition, able to reduce moisture below 15 ppm in 2 hours, below 10 ppm in 6 hours, below 5 ppm in 16 hours, below 2-3 ppm in 2 days, and as low as 1 ppm in 3-6 days.*
- ✎ System automatically compensates for power outages and starts the regeneration process over if interrupted for 10 minutes or longer. This feature ensures complete regeneration of the copper catalyst and molecular sieve since proper regeneration cannot occur if the system has cooled.
- ✎ Factory leak-tested with a mass spectrometer while pressurized with helium at 5 inches of water gauge. No detectable leaks greater than 1×10^{-6} ml/sec.
- Internal stainless steel gas purification lines have oxygen and moisture permeation below 0.1 ppm/min.
 - Achieved less than 1.67 ppm/minute oxygen permeation when using ISO 10648-2 test methods at -4 inches of



water gauge on Protector Fiberglass and Stainless Steel and Precise Controlled Atmosphere Glove Boxes. Lowest attainable oxygen levels are 0.2 ppm for stainless steel, 0.4 ppm for fiberglass, and 3.5 ppm for polyethylene. Lowest attainable moisture levels are 1 ppm for stainless steel, 2 ppm for fiberglass and 5 ppm for polyethylene.*

- Vacuum pump outlet is rated at 115 volts, 8 amps or 230 volts, 4.5 amps.
- Three microprocessor-controlled solenoid valves, located on the back, for connection to 4% hydrogen/inert gas mixture, vacuum pump and vent exhaust.
- ✎ Communications port, located on the back, allows for shared access to the vacuum pump with the glove box. An optional accessory 6-Pin Cable 5442000

is available for communication between the AtmosPure and Auto Pressure Controller of the Protector Controlled Atmosphere Glove Box or accessory Auto Pressure Controller used with the Precise Glove Box.

- Flow control valve sets 4% hydrogen/inert gas mixture between 10-25 CFH.
 - Blower button toggles circulation gas purifier blower between ON, OFF and AUTO. ON allows the blower to run continuously, OFF shuts the blower off, and AUTO allows the blower to be programmed for auto mode and controlled by the oxygen or moisture control ranges.
 - Start/Stop button initiates and ends the 13 hour regeneration process.
 - Regeneration heater delivers 180 watts for 5 hours of the 13 hour regeneration cycle.
 - 3/4" Inlet/outlet compression fittings for connection to Protector Fiberglass or Stainless Steel Controlled Atmosphere Glove Boxes. Accessory 3/8" adapter is available for connection to Precise Controlled Atmosphere Glove Boxes or other glove box models.
 - ✎ Compact dimensions. Designed to fit on the accessory Glove Box Base Stand beneath the transfer chamber without interfering with the operator's leg space. Dimensions: 14.9" w x 31.8" d x 21.9" h (38 x 81 x 56 cm).
 - Durable epoxy-coated steel housing.
 - ETL listing. UL 61010-1 and CAN/CSA C22.2 No. 1010.1 conformity (North America models).
 - CE Conformity Marking (International models).
 - Shipping weight 90 lbs. (41 kg)
- See page 18 for AtmosPure accessories.*

✎ Exclusive Feature *Results were attained at Labconco Corporation under controlled conditions. Actual results may vary.

Catalog Number	Electrical Requirements	Plug Type
5121810	100-115 volts, 50/60 Hz	North America, 100-115 Volts
5121831	208/230 volts, 50/60 Hz	British (UK)
5121835	208/230 volts, 50/60 Hz	Schuko
5121840	208/230 volts, 50/60 Hz	China/Australia
5121845	208/230 volts, 60 Hz	North America, 208-230 Volts

Plug Configurations & Electrical Requirements

North America, 110-115 volts
100-115 volts, 50/60 Hz,
10 amps



British (UK)
208-230 volts, 50/60 Hz,
10 amps

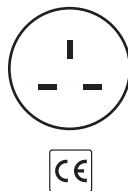

Schuko
208-230 volts, 50/60 Hz,
10 amps

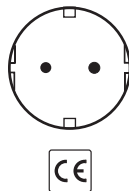

China/Australia
208-230 volts, 50/60 Hz,
10 amps



North America, 208-230 volts
208-230 volts, 60 Hz,
10 amps



AtmosPure™ Re-Gen Gas Purifiers

ACCESSORIES

5441500 AtmosPure Roughing Prefilter Kit. Filters the inlet and outlet of the glove box as the inert gas is purified. Includes two roughing prefilters and clamp plates to mount inside Protector Glove Boxes. Shipping weight 5 lbs. (2 kg)

5441600 AtmosPure P100 Particulate Filter Kit. Filters the inlet and outlet of the glove box as the inert gas is purified. Includes two P100 particulate filters and mount housings. Shipping weight 5 lbs. (2 kg)

5441700 AtmosPure Regeneration Plumbing Kit. Includes flexible tubing and fittings required to make the regeneration plumbing connections to the 4% hydrogen/inert gas mixture, vacuum and vent. Shipping weight 2 lbs. (1 kg)

AtmosPure Circulation Tubing Kits. Include the plumbing to make the connection from the AtmosPure to the glove box.

AtmosPure 3/4" to 3/8" Adapter Kits. Fittings permit 3/4" ID neoprene hose included with 5441800 and 5441801 Kits (sold separately above) to attach to glove box's 3/8" inlet/outlets. Two fittings included with each kit. Not required on current Protector Glove Boxes (manufactured after November 2010).

Catalog #	Description	For Use with	Shipping Wt.
5441900	Elbows	Precise Glove Boxes	5 lbs. (2 kg)
5441901	Reducers	Pre-2011 Protector Glove Boxes	5 lbs. (2 kg)

5442000 AtmosPure 6-Pin Communication Cable. Required for use when AtmosPure and glove box configured with Auto Pressure Controller are sharing one vacuum pump. Shipping weight 2 lbs. (1 kg)

5442100 AtmosPure 9-Pin Oxygen/Moisture Monitor Cable. Required for use when the AtmosPure is used in AUTO mode. Allows for automatic control of the AtmosPure blower from an accessory Oxygen or Moisture Monitor (sold separately). Shipping weight 2 lbs. (1 kg)

Catalog #	Circulation Tubing Kit Description	For Use with	Shipping
5441800	3/4" ID Neoprene-lined flexible hose	All glove boxes, single width	5 lbs./2 kg
5441801	3/4" ID Neoprene-lined flexible hose	All glove boxes, double width	8 lbs./4 kg
5441802	3/4" OD Stainless steel, hard-ducted	Protector Glove Boxes, single width	10 lbs./5 kg
5441803	3/4" OD Stainless steel, hard-ducted	Protector Glove Boxes, double width	20 lbs./9 kg

Protector® Controlled Atmosphere & Combination Glove Boxes

ACCESSORIES

Automatic Pressure Controllers. For use with Protector Controlled Atmosphere Glove Boxes without Automatic Pressure Controller. Easily reduce glove box oxygen and moisture levels by automating the evacuation/purge process. Automatically regulate pressure and vacuum within the main chamber and transfer chamber and auto-



mate evacuation/fill cycles up to 499 for the main chamber and 199 for the transfer chamber. Vacuum and pressure may be regulated between -5 to +5 of w.g. in the main chamber and between 0 to -29 inches of mercury in the transfer chamber. A mutable, audible alarm

sounds when pressure/vacuum level is outside set limits. Consist of epoxy-coated steel casing with a front panel LCD display and a rear panel with power switch, power inlet connection with circuit breakers, electrical receptacle for connection to vacuum pump (sold separately), electrical connection for foot pedal, two solenoid valves for controlling gas in and gas/vacuum out to transfer chamber, and two solenoid valves for controlling gas in and gas/vacuum out to main chamber. Unit of measure display options are inches of water, inches of mercury, and mBar. A three-position foot pedal (increase gas/fill, off, evacuate/decrease gas) provides hands-free control of the gas inlet and vacuum outlet valves. Include mounting bracket, 3/16" ID polyvinyl tubing, 3/32" ID polyvinyl tubing, and power cord with plug. Shipping weight 20 lbs. (9 kg)

Catalog #	Electrical Configuration
5238600	100/115 volts, 50/60 Hz operation
5238601	230 volts, 50/60 Hz operation



Gas and Vacuum Tubing Connection Kits

Include the flexible vinyl tubing and fittings necessary to connect user-supplied inert gas supply tank and rotary vane vacuum pump to valves located on the glove box.

Catalog #	Description	For Use with	Shipping Wt.
5245100	Manual Valve Gas and Vacuum Connection Kit	All Protector Glove Boxes	2 lbs. (0.9 kg)
5245200	Automatic Pressure Controller Gas and Vacuum Tubing Connection Kit	5238600 5238601	2 lbs. (0.9 kg)

5075619 Electrical 9-Pin Sealed Pass-Through Kit. Provides a leak-tight connection for data transfer from an electronic device inside the glove box to computer, printer or other electronic device outside the glove box. For example, an interior-mounted Oxygen or Moisture Monitor may transfer data through the Pass-Through port to the AtmosPure Re-Gen Gas Purifier connected to a 5442100 Cable. Includes sealed 9-pin connector (D-subminiature with male pins on one side and female pins on the other) and 10' cord. Shipping weight 1 lb. (0.5 kg)

Protector® Controlled Atmosphere & Combination Glove Boxes

ACCESSORIES



Direct Drive Rotary Vane Vacuum Pumps

For evacuating the main chamber and/or transfer chamber. Displacement is 117 liters/minute at 60 Hz and 98 liters/minute at 50 Hz. Ultimate vacuum (total pressure) is 2×10^{-3} mBar (1.5 micron). Consist of on/off switch; two inlet

adapters (1/2" and 3/4" OD); mode selector with High Vacuum and High Throughput positions; and gas ballast with closed, low flow and high flow positions. Single phase, direct drive motor, totally enclosed and fan cooled. Thermal overload device switches off the pump when overheated and automatically restarts when cooled. Isolation valve seals the inlet and prevents oil and air contamination of the system in the event of a power failure. Constructed of cast aluminum casing with lift handle and rubber feet. Include four bottles (1 liter each) of vacuum pump oil, one exhaust filter with oil mist and odor filter elements. Dimensions: 6.5" w x 17.0" d x 10.4" high (16.5 x 43.2 x 26.4 cm). Shipping weight 62 lbs. (28 kg)

Catalog #	Electrical Configuration
1472100	115 volts, 50/60 Hz, 4.6 A. Includes 115 volt NEMA 5-15 plug.
7739400	230 volts, 50/60 Hz, 2.4 A. Includes 230 volt NEMA 6-15 plug.
7739402	230 volts, 50/60 Hz, 2.4 A. Includes 230 volt reverse IEC plug.

Exterior Monitor Tubing Kits. Provide attachment tubing to allow placement of Oxygen or Moisture Monitors outside the glove box. Shipping weight 5 lbs. (2 kg)

Catalog #	Description
5442400	For use with Oxygen Monitor 5244500 and 5244501
5442500	For use with Moisture Monitor 5244900 and 5244901



Moisture Monitors, 0-10,000 ppm

Measure absolute moisture content in gas. Detect levels from 0 to 10,000 ppm (with three ranges from 0-100 ppm, 100-1000 ppm, and 1000-10,000 ppm) with $\pm 1\%$ accuracy. Consist of chemically-inert ceramic technology moisture monitor, sampling block, digital display monitor, sampling pump, switching power

supply and on/off switch. For placement inside the glove box's main chamber unless plumbed with Kit 5442500 (sold separately). Dimensions: 7.7" w x 9.0" d x 7.2" high (19.6 x 22.9 x 18.3 cm). Shipping weight 13 lbs. (6 kg)

Catalog #	Electrical Configuration
5244900	110/115 volts, 50/60 Hz operation
5244901	230 volts, 50/60 Hz operation



Moisture Monitors, 0-6000 ppm

Measure dew point range from -80 to 0° C or 0 to 6000 ppm. Display dew point only. Include meter, probe, attachment plug, and calibration stand. For placement inside the glove box's

main chamber. Dimensions: 5.5" w x 8.0" d x 1.8" high (7.7 x 20.39 x 4.6 cm). Shipping weight 10 lbs. (5 kg)

Catalog #	Electrical Configuration
5442200	110/115 volts, 50/60 Hz operation
5442201	230 volts, 50/60 Hz operation



5244800 Hand-held Digital Hygrometer

Battery-operated instrument measures both percent relative humidity from 0.1-100% with $\pm 2\%$ accuracy and temperature in ° F or ° C with $\pm 1^\circ$ F ($\pm 0.5^\circ$ C) accuracy. Calculates the dew point temperature and wet bulb temperature based on the relative humidity and temperature readings. Minimum and maximum temperature and relative humidity readings may be stored in memory. Hold function freezes reading. Memory function

stores up to 25 sample readings. Includes 9 volt alkaline battery. Shipping weight 1.5 lbs. (0.7 kg)



Oxygen Monitors, 0-10,000 ppm

For detecting trace oxygen levels using an electrochemical sensor. Provide a digital readout in three measurement ranges of 0-100 ppm, 100-1000 ppm and 1000-10,000 ppm. Accuracy is $\pm 1\%$ of full scale. Readout displays on 4 1/2 digit LCD. Equipped with three user-configurable oxygen alarm relays and one user configurable status alarm relay. Include audible alarm and

three front panel LED visual alarms. 4-20 mADC and 0-2 VDC analog outputs. Casing is watertight polycarbonate with gasketed seals. Gas inlet and outlet connections are 1/4" stainless steel compression fittings. Dimensions: 8.3" w x 6.2" d x 10.9" high (21.1 x 15.7 x 27.7 cm). For placement inside the glove box's main chamber unless plumbed with Kit 5442400 (sold separately). Shipping weight 13 lbs. (6 kg)

Catalog #	Electrical Configuration
5244500	110/115 volts, 50/60 Hz operation
5244501	230 volts, 50/60 Hz operation



5244400 Oxygen Monitor, 0.1-100%

Measures percent of oxygen inside the glove box using a chemical-resistant electrochemical sensor. Front LCD panel displays percentage from 0.1 to 100%. Includes interconnecting sensor cable and power cord for connection to the glove box's interior electrical receptacle. Measurement range is 0.1

to 100% oxygen ($\pm 1\%$ of full scale at 77° F and 29.92" Hg). Rated for general purpose service as low as 1000 ppm (0.1%). Mounting bracket is provided for hanging from Rear Interior Shelf Kit 5235000 (sold separately). Dimensions: 6" w x 1.5" d x 5.5" high (15.2 x 3.8 x 14.0 cm). For 115/230 volt, 50/60 Hz operation. Shipping weight 3.5 lbs. (1.6 kg)

Protector® Controlled Atmosphere & Combination Glove Boxes

ACCESSORIES

Drying Trains

Provide a means for reducing the humidity within the glove box to less than 5 ppm (rated for achieving a dew point of -65° C).

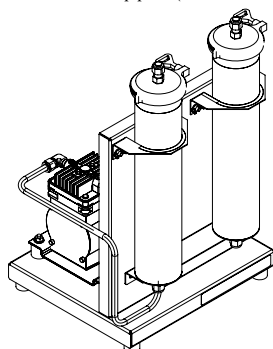

Include 1 CFM diaphragm pump, stainless steel column with molecular sieve (one or two depending on model), stainless steel tubing to connect column to pump and 3-wire cord and plug. An on/off switch is located on the cord on 115 volt models. **3/8" OD copper tubing and two isolation valves are required.**

Catalog Number	Electrical Requirements	Number of Columns	Shipping Weight
5061300	115 volts, 60 Hz, 3.15 amps	1	15 lbs. (6.8 kg)
5061301	115 volts, 60 Hz, 3.15 amps	2**	17 lbs. (7.7 kg)
5061302*	230 volts, 50 Hz, 1.55 amps	1	15 lbs. (6.8 kg)
5061303*	230 volts, 50 Hz, 1.55 amps	2**	17 lbs. (7.7 kg)

*International electrical configuration **One column is in use while the second column is regenerating.

5117000 Optional Second Column

Stainless steel column that contains molecular sieve rated for achieving a dew point of -65° C. Provides immediate replacement column for Drying Train 5061300 or 5061302. Shipping weight 5 lbs. (2.3 kg)

7837300 Molecular Sieve Replacement Media

For replacing spent media in Drying Train column. Provides two refills. Shipping weight 6 lbs. (2.7 kg)



Drying Train Accessories

A chemical trap to remove organic solvents, acids, ammonia, radioisotopes or moisture may be added to any glove box. The trap is connected to two main chamber valves and a diaphragm pump for recirculation of the main chamber atmosphere and contaminant removal. **Diaphragm vacuum pump is required.**

Catalog #	Description	Shipping Wt.
7815301	Canister with Stand accommodates any trap insert listed below. Clear polypropylene canister allows visual inspection of trap contents.	5 lbs. (2.3 kg)
7815200	Moisture & Solvent Trap Insert. Contains molecular sieve to provide less than 50 ppm moisture.	4 lbs. (2 kg)
7814800	Acid Trap Insert. Contains acid neutralizing desiccant that changes from off-white to purple when exhausted.	4 lbs. (2 kg)
7815000	Radioisotope Trap Insert. Contains activated carbon.	4 lbs. (2 kg)
7995600	Ammonia Trap Insert. Contains impregnated carbon.	4 lbs. (2 kg)



5242500 Drying Train Tubing Kit

Includes 25' x 3/8" OD fluorinated ethylene propylene (FEP) tubing and eight tube inserts to connect drying train components. Shipping weight 3 lbs. (1.4 kg)



5244100 Flowmeter

For inline drying train connection to provide visual confirmation of drying train circulation. Shipping weight 2.5 lbs. (1.1 kg)



5240100 Gas and Vacuum 0.2 Micron Filter

Traps particulates. For drying train or vacuum pump exhaust. 0.25" - 0.38" ID. Shipping weight 0.5 lb. (0.2 kg)



Diaphragm Vacuum Pumps

For drying train circulation. Single cylinder, oil-free diaphragm pumps with permanently lubricated bearings and mounted on rubber feet. Provide 206 mBar ultimate vacuum. 1/8 hp motor. Die cast aluminum. 3/8" OD diameter inlet and outlet

connections. Dimensions: 4.8" w x 8.0" d x 7.0" h (12.2 x 20.3 x 17.8 cm). Shipping weight 11 lbs. (5 kg)

Catalog #	Description
5248200	Diaphragm Pump for 115 volt, 60 Hz, 3.3 amp operation, with switch. 42 L/minute displacement capacity.
5248201*	Diaphragm Pump for 230 volt, 50 Hz, 1.5 amp operation, 35 L/minute displacement capacity.

*International electrical configuration

Vacuum Pump and Pressure Relief Bubbler HEPA Filter Kits

Kits include 5" diameter round HEPA filter, 99.9% efficient on 0.3 micron particulates and two plastic hose barbs for attachment to tubing.

Catalog #	Description	Shipping Wt.
5441400	Kit with HEPA filter and 1/2" OD hose barb canister for placement between the glove box and vacuum pump to protect the pump from particulate contaminants.	10 lbs. (4.5 kg)
5441403	Kit with HEPA filter, hose barb connectors and 10' of 3/4" ID neoprene tubing for attachment to the pressure relief bubbler exhaust. Should overpressurization occur, the HEPA filter traps particulate contaminants, preventing their escape into the room.	10 lbs. (4.5 kg)
5441401	Replacement HEPA filter, 99.99% efficient on .03 micron particulates. For use with 5441400 or 5441403 Kit.	2 lbs. (0.9 kg)

Protector® Glove Boxes

GENERAL ACCESSORIES

Gloves, Sleeves and Hands



Neoprene Gloves

Highly resistant to abrasion and tearing. Impermeable to water vapor, gases and toxic chemicals. One piece, seamless, 0.015 gauge. With O-rings. One pair of size 9 3/4 is included with each Protector Glove Box.

Catalog #	Description	Shipping Wt.
5005500	Size 8 1/2, one pair	3 lbs. (1.4 kg)
5005600	Size 9 3/4, one pair	3lbs. (1.4 kg)



Butyl Gloves

Highly impermeable to water vapor, gases and toxic chemicals. Resistant to oxygenated solvents and most oxidizing chemicals. High dexterity. One piece, seamless, 0.015 gauge. With O-rings.

Catalog #	Description	Shipping Wt.
5005501	Size 8 1/2, one pair	3 lbs. (1.4 kg)
5005601	Size 9 3/4, one pair	3lbs. (1.4 kg)



Hypalon Gloves

Mixture of neoprene and butyl. Resistant to abrasion, ozone and oxidizing chemicals. One piece, seamless, 0.015 gauge. With O-rings.

Catalog #	Description	Shipping Wt.
5005502	Size 8 1/2, one pair	3 lbs. (1.4 kg)
5005602	Size 9 3/4, one pair	3lbs. (1.4 kg)



5005603 Latex Gloves

For use when dexterity is needed. Limited protection. Size 9 3/4. One piece, seamless, 0.015 gauge. With O-rings. One pair. Shipping weight 3 lbs. (1.4 kg)



5005800 Neoprene Straight Sleeves

For use with any Hands listed at right. With O-rings and springs. One pair. Shipping weight 3 lbs. (1.4 kg)



5005900 Neoprene Accordion Sleeves

For use with any Hands listed at right. With O-rings and springs. One pair. Shipping weight 3 lbs. (1.4 kg)



Neoprene Hands

Lightweight, embossed with firm-hold finish. For use with either Neoprene Straight or Accordion Sleeves, 0.017 gauge.

Catalog #	Description	Shipping Wt.
5006000	Size 7 1/2, package of 12 pairs	2 lbs. (0.9 kg)
5006100	Size 9, package of 12 pairs	2 lbs. (0.9 kg)
5033100	Size 10, package of 12 pairs	2 lbs. (0.9 kg)



Latex Hands

White, surgical-type. For use with either Neoprene Straight or Accordion Sleeves, 0.009 gauge.

Catalog #	Description	Shipping Wt.
5006200	Size 7, package of 12 pairs	2 lbs. (0.9 kg)
5006300	Size 9, package of 12 pairs	2 lbs. (0.9 kg)



5242200 Exterior Glove Port Covers

May be placed over glove ports with or without gloves attached to

facilitate and expedite the evacuation/fill operation and preserve inert atmosphere. Molded rubber. Includes two clamps. Set of two. Shipping weight 3.5 lbs. (1.6 kg)



5060400 Interior Glove Port Cover

Quickly seals glove box should sudden leak occur due to glove damage. Stainless

steel with molded rubber gasket and spring-loaded latches with adjustable closure knob. Shipping weight 8 lbs. (3.6 kg)



5066700 Polycarbonate Viewing Window

Polycarbonate, 0.4" thick (1 cm), with dry powder epoxy-coated steel frame, replaces standard laminated glass window. Viewing

dimensions: 36.0" w x 27.7" high (91.4 x 70.4 cm). Shipping weight 120 lbs. (54 kg)

Protector® Glove Boxes

GENERAL ACCESSORIES



5225701 Add-A-Valve Kit
Includes the manual ball valve, compression fitting, hose connector fitting, O-ring and nut to add a service valve to the main chamber. **Requires installation and 0.688" diameter hole.** Valve may be used for a variety of services including vacuum, gas, nitrogen, air, carbon dioxide or cold water. Shipping weight 1 lb. (0.5 kg)



Anti-Static Ionizer Fans
Circulate ionized air inside the glove box to reduce static charge. **Require installation.** Shipping weight 5 lbs. (2 kg)

5225703 Add-A-Valve Installation Kit

Includes 0.688" diameter hole saw, arbor and instructions. For use with fiberglass-lined glove boxes only. Shipping weight 0.5 lb. (0.2 kg)



Electrical Power Strips
Provide electrical receptacles for connecting instruments and equipment inside the glove box. Include an electrical cord and plug for connection to the glove box's interior receptacle. Shipping weight 3 lbs. (1.4 kg)

Catalog #	Description
5211500	North American Electrical Configuration, 115 volts, 50/60 Hz, 10 amps, 4 receptacles
5210601	British (UK) Electrical Configuration, 208-230 volts, 50/60 Hz, 10 amps, 6 receptacles
5290401	Schuko Electrical Configuration, 208-230 volts, 50/60 Hz, 10 amps, 4 receptacles
5332601	China/Australia Electrical Configuration, 208-230 volts, 50/60 Hz, 10 amps, 6 receptacles

Catalog #	Description
5234400	For 100/115 volt, 50/60 Hz operation, with 24 VDC power supply
5234401	For 230 volt, 50/60 Hz operation, with 24 VDC Schuko power supply

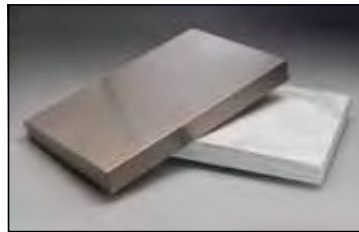

5234600 Balance Vibration Isolator
Minimizes vibration to sensitive balances. Includes a 13.4" w x 20.4" d x 2.7" thick (34.0 x 51.8 x 6.9 cm) marble slab, four isolator pads, and a type 304 stainless steel protective cover. Shipping weight 75 lbs. (34 kg)



5075619 Electrical 9 Pin Sealed Pass-Through Kit
Provides a leak-tight connection for data transfer to a customer-supplied printer or computer located outside the glove box. Includes sealed 9 pin connector (d-subminiature with male pins on one side and female pins on the other) and 10' cord. **Requires drill hole.** Shipping weight 1 lb. (0.5 kg)



5061600 Interior Shelves Kit
Provides shelf space across the back wall of the glove box interior. Three stainless steel storage shelves are attached to epoxy-coated steel upright supports. Shelves have adjustable height and measure 30" wide x 6" deep (76.2 x 15.2 cm). Installation hardware and instructions are included. Shipping weight 15 lbs. (6.8 kg)

5240800 Installation Kit for Electrical Pass-Through

Includes drill bits for installing Electrical Pass-Through on a fiberglass-lined glove box. Shipping weight 0.5 lb. (0.3 kg)

Protector® Glove Boxes

BASE STANDS



Adjustable Height Base Stands

Support Protector Glove Boxes. Available with casters or leveling feet. Durable 2" tubular glacier white epoxy-coated steel frame has lower shelf, 47" w x 18" d (119.4 x 45.7 cm), with 17" w x 27" d (43.2 x 68.6 cm) area on right-hand side to support optional AtmosPure Re-Gen Gas Purifier. Telescoping legs adjust in 1" increments to seven overall height positions from 33.0" to 40.0" (83.8 x 101.6 cm). Black laminate hard board work surface, 60.0" w x 31.0" d (152.4 x 78.7 cm) is permanently mounted to the frame. Shipping weight 225 lbs. (102 kg)

Catalog #	Description
5235500	Adjustable Height Mobile Base Stands with 5" diameter, toe-locking ball-bearing polyurethane casters.
5235501	Adjustable Height Stationary Base Stand with leveling feet. Overall depth: 31.0" (78.7 cm)

5235500 Adjustable Height Mobile Base Stand

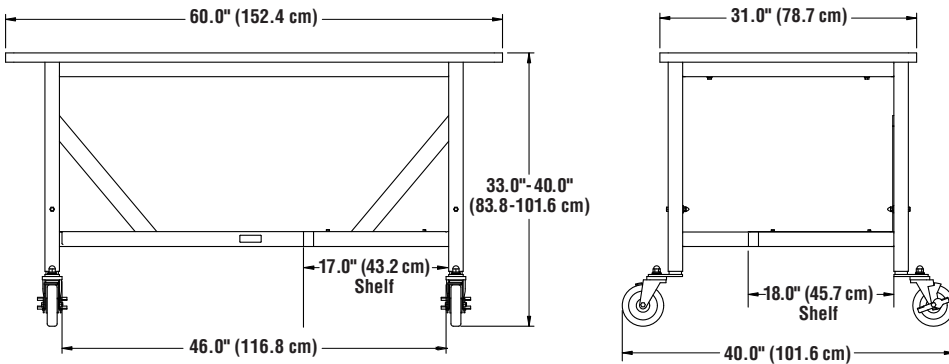

5235501 Adjustable Height Stationary Base Stand

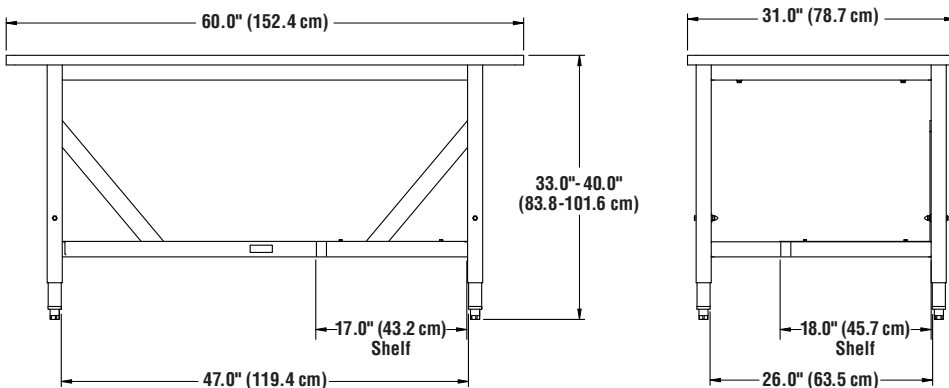

Protector® Glove Boxes

DOUBLE MOBILE BASE STAND & LEFT SIDE DOOR OPTION



5062020 Double Mobile Base Stand

Supports Protector Double Glove Boxes. Durable 2" tubular glacier white epoxy-coated steel frame has lower shelf, 54.3" w x 23" d (137.9 x 58.4 cm), with 16" w x 29" d (41 x 74 cm) area on right-hand side to support optional AtmosPure Re-Gen Gas Purifier. Includes 5" diameter, toe-locking, non-marking polyurethane casters with ball bearings for quiet operation. When ordered with a Protector Double Glove Box, the Stand ships premounted to the glove box. Shipping weight 400 lbs. (181 kg)

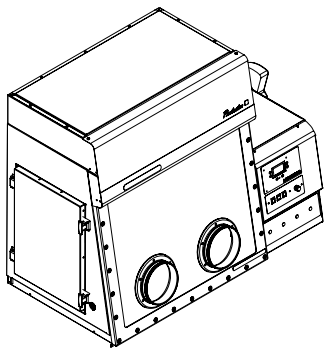
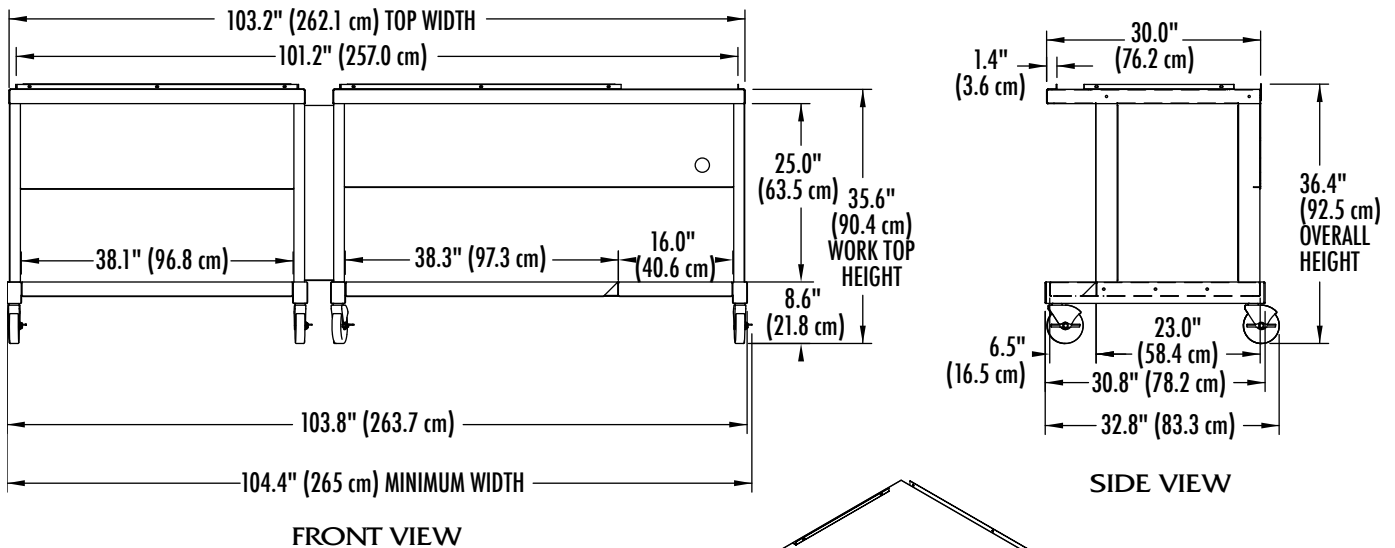

Left Side Door Option

Any stainless steel-lined Protector Glove Box may be factory prepared with a large left side door for use in loading large equipment. It provides a convenient alternative to removing the window and frame to load oversized items. The left side door has an opening of 16.5" wide x 23.2" high (41.9 x 58.9 cm). Contact Labconco for ordering information.

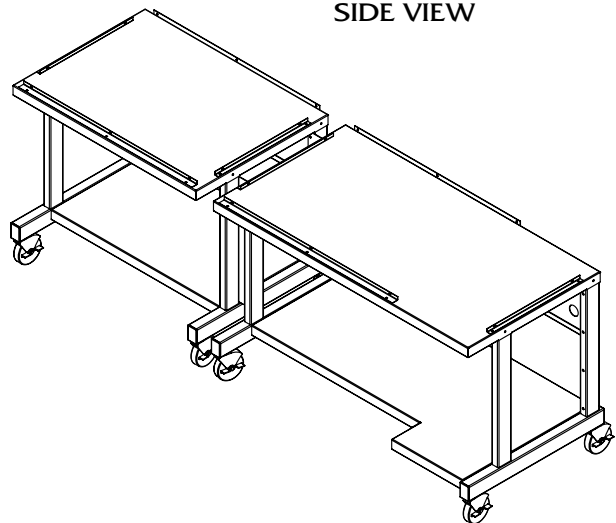

Contact Labconco for More Information

PRECISE® GLOVE BOXES



Precise® Glove Boxes are constructed of durable molded polyethylene. Over 70 accessories allow these glove boxes to be customized to fit application requirements.

Contact Labconco for more information about these quality products for your Laboratory.



Precise® Glove Boxes



Fume Hoods & Ductless Enclosures



Balance & Bulk Powder Enclosures



Biological Safety Cabinets, Enclosures & Clean Benches



Laboratory Animal Research Stations



Nanotechnology Enclosures



Glassware Washers



Water Purification Systems



Freeze Dry Systems



Vacuum Concentrators & Cold Traps



Multiple Sample Evaporation Systems



Laboratory Carts & Mobile Benches



Blood Drawing Chairs



Agricultural Chemistry Products



Vacuum Desiccator



Protecting your laboratory environment

LABCONCO®

Labconco Corporation

8811 Prospect Avenue
 Kansas City, Missouri 64132-2696
 816.333.8811 or 800.821.5535
 Fax: 816.363.0130
 www.labconco.com



© 2011 by Labconco Corporation. Printed in the U.S.A.
 Product design subject to change without notice.

2-49-4/11-SUN-7M-R1